

MV Univers

ISO -5 class 100 Cleanliness level vertical flow cabinet

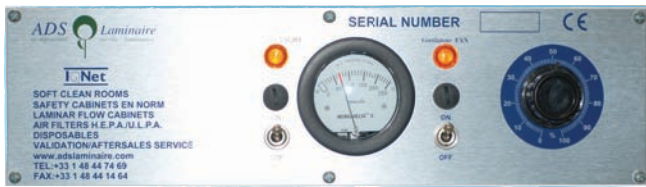

CONTROL PANEL

Main control panel is located in the center of the filtration unit and includes:

- On/off switch for the fan + indication light.
- On/off switch for the lighting + indication light.
- Speed regulator for the fan to control the down flow air velocity.
- Manometer.
- Fan fuse.
- Lighting fuse.

FAN

- Very robust adjustable fan.
- No maintenance required thanks to its construction.
- The static and dynamic balance between the impeller and the motor enables nonstop utilization at a very low noise level.
- The choice of this fan guarantees constant flow rate during the absolute filter's life span.

LIGHTING

- One fluorescent light bulb installed at the top of the chamber.
- Provides 500-600 LUX on the working area.

PRE FILTER

- G-3 efficiency according to EN 779 norm prefilter is installed at the air inlet of the cabinet.
- Filter frame: cardboard.
- Filter size: 305mm (W) +760mm (L) +20mm (D).

ABSOLUTE FILTER (MINIPEAT)

- Efficiency: H-14 according to EN-1822
- Protection grid: Epoxy painted protection grid
- Frame: Anodized aluminum
- Sealant: Polyurethane
- Tightness Blue gel

BLUE GEL SEALING

The tightness between the filter and the fan unit is ensured by a gel fluid gasket, well known in the industry. This gel gasket is usually called blue gel because of its color, guarantees the unit to be leak free. Moreover, the maintenance of the absolute filter is easier, as no tools are needed.

MAINTENANCE

No special maintenance is needed, except for replacing the W pre-filter and the HEPA filter. This task is fast and simple due to the special gel sealing method of the HEPA filter.

PREFILTER: a average life time is 6 months. The Prefilter is located on the top of unit; allowing direct access.

HEPA FILTER: average life time is 3 years.

DIMENSIONS IN mm:

MV UNIVERS	EXTERNAL	INTERNAL
Height	1000	645
Width	918	902
Depth	592	600
Height on stand	1857mm on 857mm stand	
Weight in kg	45 without stand	

ADDITIONAL OPTIONS

- Gas / vacuum Taps
- Stand- HPL/S.S
- Working surface. 1.8m width special size.

DELIVERY OF MV UNIVERS

It is packed into a very rigid cardboard case. Included in the case is a user manual in English.

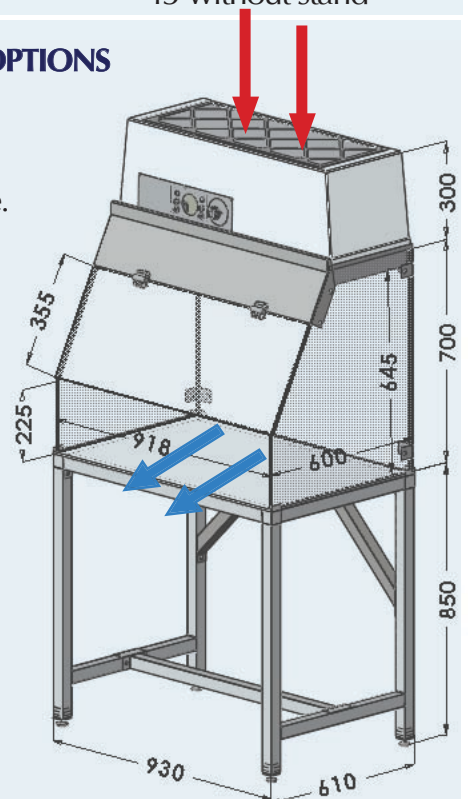

MV Univers

ISO -5 class 100 Cleanliness level vertical flow cabinet

Way choose the MV Univers?

Provides excellent protection from air contaminations.

Compact cabinet able to fit into a small area.

Enables a bench top installation, enables self easy installation.

Security glass surrounds the work area allowing a pleasant atmosphere for the worker.

Sloped Plexiglass top flip front window.

Has a HEPA filter with a gel sealant fitting which guarantees tightness and enables easy maintenance service.

Low energy consumption.

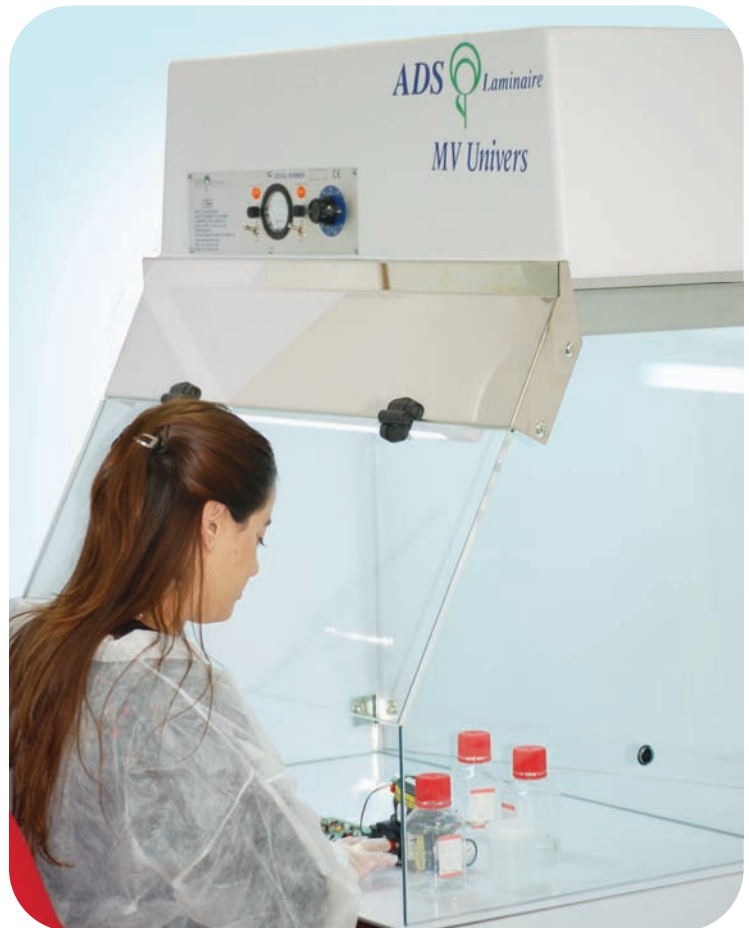

Sectors Of Use

- Botanic
- Optics
- Food Industry
- Pharmaceuticals
- Defense and Aviation
- Research Centers
- Health and Hospitals
- Chemistry
- Microelectronics
- Micro-mechanics

GENERAL DESCRIPTION

The MV UNIVERS is the most economic and compact vertical flow clean cabinet that is manufactured by ADS LAMINAIRE which provides ISO-5 cleanliness level according to ISO 14644 norm (class 100 according to F.S 209).

The principle function of the cabinet is by inlet air from the room through a G3 efficiency prefilter and presses the air to the plenum before the Hepa filter. The air is filtered by H-14 efficiency according to EN-1822 norm Hepa filter. As a result of the above process, ISO 5 clean level working area is obtained.